

A-TEC PMM-6 9MM PISTOL SILENCER

A-TEC is a Norwegian company with 20 years of experience with silencer manufacturing. A-TEC PMM (Pistol Modular Moderator) is a high performance silencer that is one of the lightest and most efficient pistol silencers on the market. The PMM is a silencer with a unique spring loaded piston, made to work with modern 9mm semi-auto pistols with different types of ammo.

A-TEC decided to introduce the revolutionary modular system on the PMM allowing the operator to reconfigure the silencer to shorter or longer design. The PMM has up to 6 modules that are made from light alloys. The silencer is constructed from aluminium and stainless steel.

The spring loaded piston (Nielsen device) will need to be cleaned every 300 shot, and lubed (greased) up again.

OVERALL PERFORMANCE:	36 DB(C)
SILENCER WEIGHT:	215 G
DIAMETER:	34,4 MM
OVER BARREL LENGTH:	10 MM
ADDED LENGTH:	185 MM
TOTAL LENGTH:	195 MM
MATERIAL	ALUMINIUM, STAINLESS STEEL
TREATMENT:	BLACK ANODISED
AVAILABLE CALIBRES:	9X19
AVAILABLE MOUNTING:	1/2"-28 UNEF, M13,5X1 LH, M13X1



ASSEMBLY & MAINTENANCE:

- Disassemble the parts
- Clean & degrease all parts
- Grease all threads, o-rings and the moving piston
- Assemble it together by hand, according to the exploded view

Use proper amount of molybden grease, approximately 1-2 grams

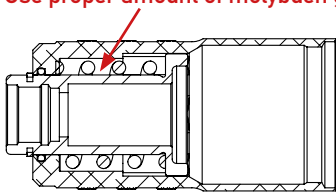

EXPLODED VIEW (PMM-2):

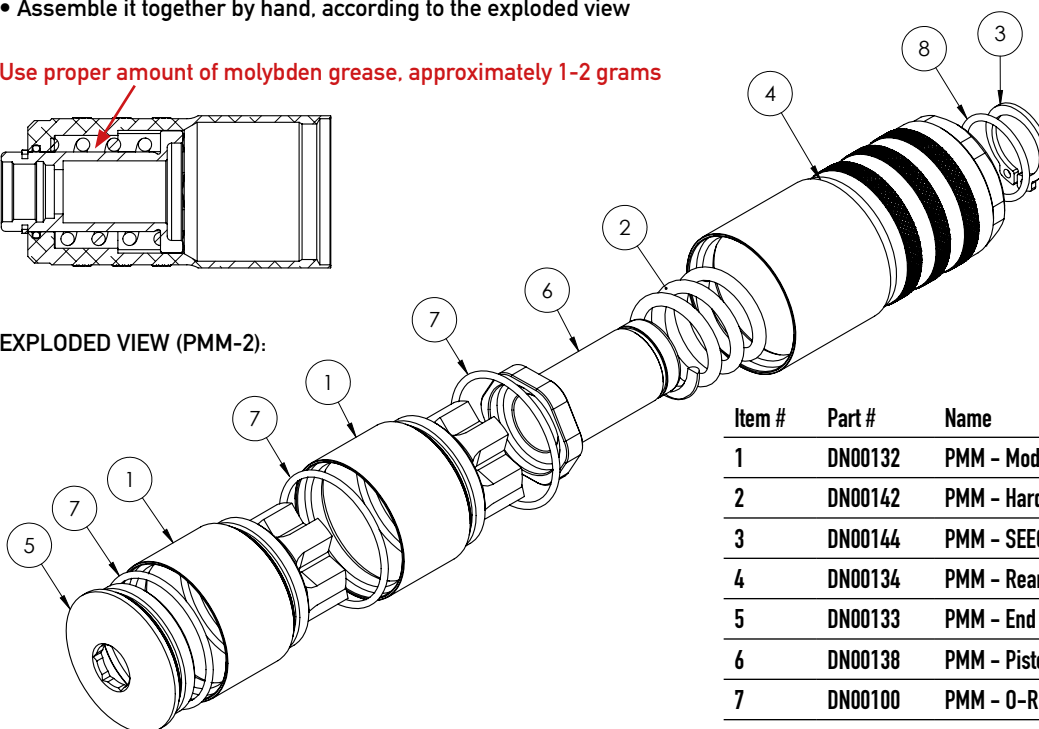

Item #	Part #	Name	No. items
1	DN00132	PMM - Module 9mm	6
2	DN00142	PMM - Hard Spring	1
3	DN00144	PMM - SEEGER Clip	1
4	DN00134	PMM - Rear Section	1
5	DN00133	PMM - End Cap	1
6	DN00138	PMM - Piston M13.5x1 LH	1
7	DN00100	PMM - O-Ring Module	7
8	DN00372	PMM - O-Ring Piston	1